

## IC-e6-PMcC PowerPC 7448 PrPMC

IC-e6-PMcC is a PrPMC mezzanine card, based on the Freescale MPC7448 processor. Compliant with our IC-e6-PMCa, it improves the memory bandwidth, provides new functions as USB2 ports and Onboard Solid-state Disk.

The MPC7448 is a high-performance embedded e600 core. These low power PowerPC processors are ideal for applications in the fields of defense, industrial automation, medical imaging.

IC-e6-PMcC can be used in conjunction with CompactPCI, VME carriers or proprietary design. Many highly integrated applications can be used on-board :

- Leading-edge computing
- Embedded network control
- Signal processing, etc.



### Description

**IC-e6-PMcC** is powered by a MPC7448, being part of the PowerPC processor family. These processors feature a high-frequency super scalar PowerPC core capable of issuing four instructions per clock cycle into 11 independent execution units : four integer units, one double-precision floating point unit, four AltiVec units, load/store and branch processing units. This e600 core provides 3200 Dhrystone 2.1MIPS @ 1,4GHz . This PowerPC also integrates 2\*32KB L1 caches and 1MB L2-ECC cache.

**IC-e6-PMcC** implements the recent DiscoveryTMV chipset to fill out the processor performances. It provides PCI-X, PCI-e bridges, DDR2 memory controller, high-speed communication controllers.

This board implements up to 1GBbytes of on-board DDR2-ECC memory with 64+8-bit access wide. For low latency CPU-to-DRAM access, the chipset implements a dedicated point-to-point, 128-bit full duplex data path, between the CPU interface and DDR2 bank of memory. The entire CPU interface and DRAM controller is running at the CPU bus clock . This implementation guarantees minimum CPU-to-DRAM latency that is critical in embedded applications.

**IC-e6-PMcC** integrates many communication functions : three Giga Ethernet channels, two USB2 channels, two UART ports, etc.

**IC-e6-PMcC** provides an onboard solid state disk useful to implement for instance large Linux file systems.

A 64-bit PCI or PCI-X controller allows the IC-e6-PMcC to be used in several PMC or PrPMC configurations in compliance with PCI 2.2 or PCI-X. This board is configurable in Monarch or non-Monarch mode.

### Main features

#### Processor Unit

- ▶ e600 core running at 1,4 GHz with :
  - L1 caches : 32KB Inst. and 32KB Data with parity
  - 1MB of L2 integrated cache
- ▶ 1GB SDRAM-DDR2 with ECC
- ▶ 128 MB soldered MirrorFlash
- ▶ PPC Real Time clock and four 32 bit-timers
- ▶ BSRAM and Calendar clock with supercap backup
- ▶ Temperature sensor and monitoring
- ▶ Two XOR DMA (useful for RAID, iSCSI)
- ▶ Four IDMA engines.

#### I/O subsystem

- ▶ Highly integrated Marvell DiscoveryTM V system controller
- ▶ Three Ethernet 10/100/1000TX ports with :
  - Support for Jumbo frames
  - One of these Ethernet ports is routed to front RJ45 and two on rear Pn4 connector.
- ▶ Dual RS232 UART
- ▶ Two USB2 (High & full speed) ports (one front & one rear)

#### Storage Subsystem

- ▶ Solid state disk based on the latest Flash Nand Technology with a dedicated flash drive controller.
- ▶ High R/W Throughput with two chips parallel access
- ▶ Up to 8 GB according to the chip availability

#### Accessories

- ▶ Engineering kit for debug : JTAG/COP and RS232 console.
- ▶ Dual PMC/XMC VME64 carrier with VME2eSST capabilities : IC-PMC-VMEa.
- ▶ cPCI 3U carrier

**IC-e6-PMcC** can be optionally provided with a Vita 42.3 (PCI-e) XMC interface

# IC-e6-PMcC

PowerPC 7448 PrPMC

## On-board firmware

The basic firmware takes in charge Freescale's new MPC7448 and the Marvell chipset Discovery V initialization. This on-board firmware, based on the open-source UBOOT, is a comprehensive set of software stored in a secured flash.

### UBoot

It is called by the reset vector when the board is powered up. It initializes the PowerPC and the DiscoveryTMV system controller, performs a comprehensive Power-on self-tests (PBIT), before to jump in different applications according to the values stored in memory. If the board acts as a Monarch PMC, the software executes an enumeration step, otherwise it waits the PCI startup sequence from the host. In standalone mode the board directly runs the configured application.

The firmware allows loading files from Ethernet via Bootp, running files in RAM or flashing them. In addition, it allows some monitor functions as : display or modify the RAM data. To end with, it enables the user to perform maintenance tests.

### IC\_Bios

This module allows the user's access to the specific **IC-e6-PMcC** hardware resources via an easy-to-use API. This module is used as a library with Vxworks and as a dynamically loaded library module for Linux.

### IC-BSP basic

These BSPs products are based on the standard distribution of the OS editor. They take in charge hardware initialization, interrupt handling and generation, hardware clock and timer services, memory management, PCI management, mapping of memory, serial ports, MAC driver for Gigabit ports.

Interface Concept provides BSP for VxWorks® (5.5 & 6.x) and Linux 2.6.x for ICLinux SDK (Linux distribution from IC). Other RTOS (LynxOS, Integrity...) can be ported on request.

## Block Diagram

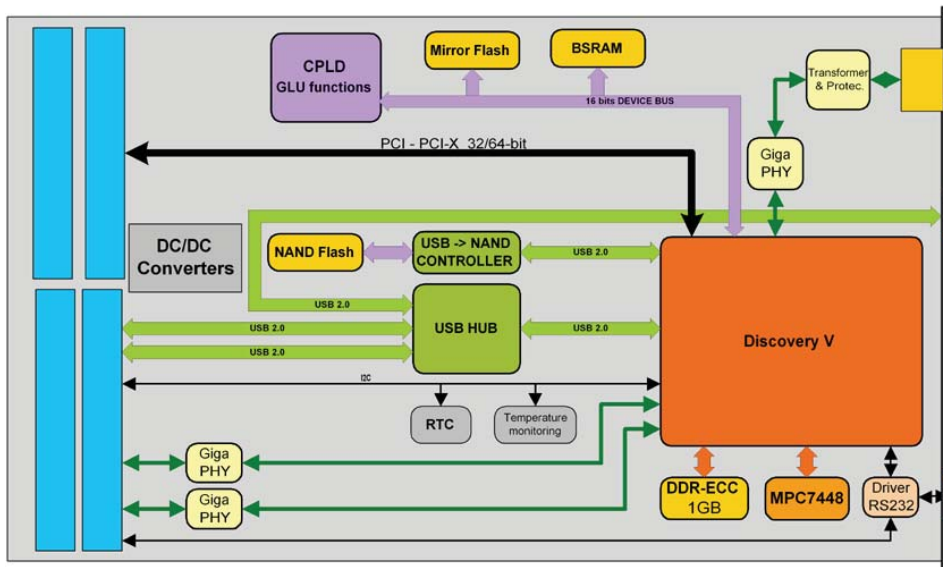

## Environnement Specifications:

Please consult the **IC-e6-PMcC** page at [www.interfaceconcept.com](http://www.interfaceconcept.com).

## Ordering Information:

Please contact our sales department : tel. +33 (0)2 98 573 030 - email : [info@interfaceconcept.com](mailto:info@interfaceconcept.com)

*This document supersedes any earlier documentation relating to the products referred to herein. The information contained in this document is current at the date of publication. It may subsequently be updated or withdrawn without notice.*

